

Cubro Packetmaster EX2 Series

PRODUCT OVERVIEW

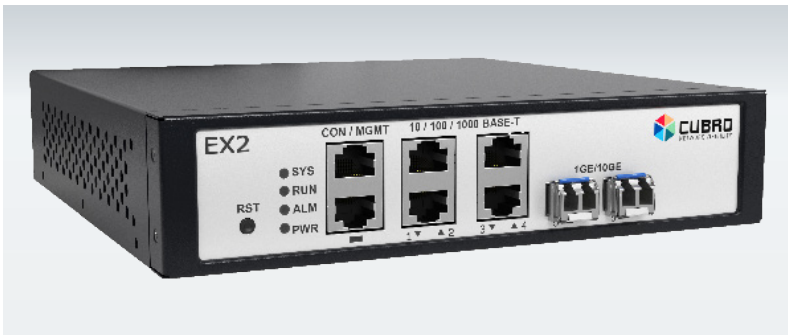

The Cubro Packetmaster EX2 series devices are Network Packet Brokers (switch-like devices) based on a newly designed ASIC and purpose-built for network traffic filtering and aggregation applications. The EX2 series provides the user much needed network visibility which allows for complete control of network traffic. The EX2 series can boost the efficiency and productivity of a company's IT team by allowing them to see what is happening on the network. Using this Network Packet Broker (NPB) a user can selectively forward only the relevant traffic to monitoring tools for precise analysis of any part of the network.

One of the primary challenges facing telecom operators is the ability to receive control information from remote base stations. Generally, Network Packet Brokers are not portable enough to conveniently carry to different base stations. The EX2 series is the only highly portable NPB that offers 10G interfaces (2 x 1/10G SFP/SFP+ in addition to 4 x 10/100/1000 copper ports) and software features equivalent to full-sized 19" rack mounted units. With the EX2 and EX2+ telecom operators increase their ability to troubleshoot issues with much needed visibility into base station traffic.

Functions / Benefits:

- Provides network visibility by aggregating, tapping and filtering traffic
- The only fully-featured portable "field" Packet Brokers on the market.
- More ports than a typical Aggregation TAP
- Fail safe when paired with a Cubro Copper TAP
- EX2+ model features an integrated one link Multimode TAP and one link Singlemode TAP
- The Packetmasters can function as media and speed converters
- IPv4 and IPv6 support included

Network Packet Broker (NPB) At a glance

Definition

A network packet broker (NPB) is a tool that receives data from number of network links; duplicates, aggregates and filters that data for the monitoring tools.

Advantages of EX2/EX2+

- Very portable
- Same feature set as full 1RU units
- Graphical user interface (GUI)
- Filters and load-balances traffic from a 10 Gbps link to multiple 1 Gbps monitoring tools
- Up to 2000 parallel rules
- IPv6 support
- Support of any kind of SFP and SFP+ (also 10 Gbit BASE-T)
- Built in Singlemode and Multimode TAPs (EX2+)
- Non-blocking 48 Gbit backplane
- Desktop usage (fanless design)
- No additional port licensing fees or software feature licensing. All features and applications included in the unit price.
- 2-year warranty period

PRODUCT CAPABILITIES / FEATURES

Link/Port Aggregation	Aggregation of up to 4 ports or 2 links 10/100/1000 Mbit to 2 x 1/10 Gbit to a single or multiple output ports.
EX2+	(EX2+ - 1 link SM 80/20 + 1 Link MM50/50)
10 Gbit traffic demultiplexer	If highly loaded 10 Gbit links have to be monitored, the traffic can be easily demultiplexed into 4 low traffic Gbit links.
Jumbo Frame Support	The Packetmaster supports jumbo Ethernet frames with a size of up to 9000 bytes.
Ports	4 x 10/100/1000 Base-T 2 x SPF+ 1/10 Gbit (2 X 10 GbitBase_T) 1 x 10/100/1000 Base-T (Management) 1 x RS232 Console
Configuration / Communication	Web GUI REST API CLI via SSH, Telnet, or Serial interface
Bandwidth	48 Gbps backplane
Aggregation latency	Average 700 ns for 64-byte frames
MTBF	198,185 hours
Rugged desktop housing	The EX2/EX2+ has a rugged chassis with precise connector labelling on the front panel.



hkaco.com



关注我们

需要详细信息? 请通过sales@hkaco.com联系我们 | 电话: 400-999-3848

办事处: 广州 | 北京 | 上海 | 深圳 | 西安 | 武汉 | 成都 | 沈阳 | 香港 | 台湾 | 美国

TECHNICAL DATA / SPECIFICATIONS

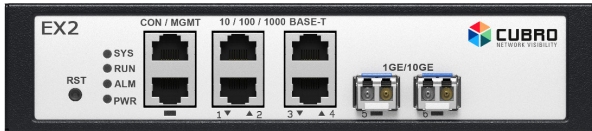

Operating specifications:

Operating Temperature: 0°C to 40°C
Storage Temperature: -10°C to 70°C
Relative Humidity: 10% min, 95% max (non-condensing)

Mechanical specifications:

Dimension (WxDxH): 201 x 201 x 44 mm
Weight: 1,35 kg
Airflow: Front-back

Electrical specifications:

Input Power: 2 x 12 DC (1 AC/DC Adaptor included)
Maximum Power Consumption: 18W

Certifications:

Fully RoHS compliant CE compliant
Safety - UL60950-1/CSAC22.260950-1-07/IEC60950-1(2005)EN 60950-1 (2006)

EX2+:

Optical TAPs transport case included (no SFP)

INPUTS*

4 x 10/100/1000 full duplex Base-T
2 x 1/10 Gbps full duplex SFP/SFP+ Ports for any kind of SFP/SFP+
*Each port can be input or/and output depending on the application and configuration

OUTPUTS*

4 x 10/100/1000 full duplex Base-T
2 x 1/10 Gbps full duplex SFP/SFP+ Ports for any kind of SFP/SFP+
*Each port can be input or/and output depending on the application and configuration

PERFORMANCE

Performance up to 48 Gbps
Non-blocking design
Estimated boot time up to 180 sec
Packet delay through processing less than 700 ns

MANAGEMENT

RJ45 10/100 Mbps; ssh and/or Web GUI
RS-232 Serial; CLI

APPLICATIONS / SOLUTIONS



10 Gbit link monitoring

The EX2/EX2+ receives traffic from a 10G or 1G optical live link via the monitor ports of a Cubro Optical TAP. By implementing filters the user can isolate only the traffic necessary to troubleshoot a network problem. The traffic can be forwarded to the 4 x 10/100/1000 Mbit Base-T interfaces and captured with a laptop running a protocol analyzer such as Wireshark or TCPDump. Alternatively the traffic can be forwarded to the unused Tx interfaces of the Optical SFPs for output to 1G or 10G optical tools.

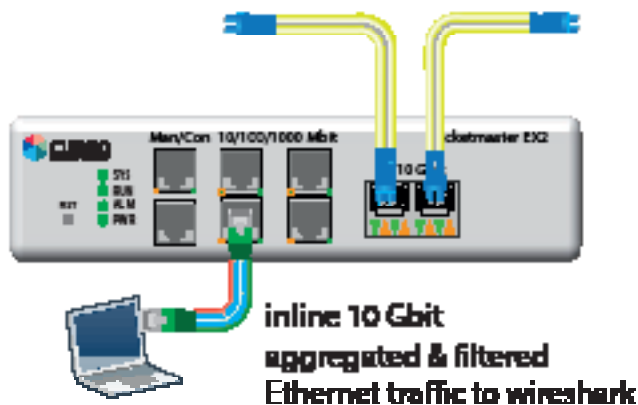
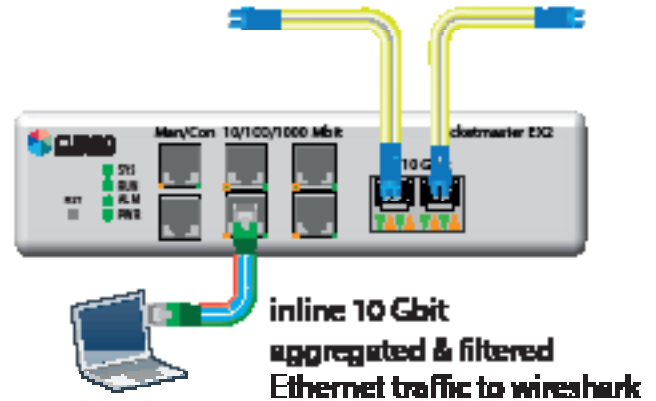

10 Gbit monitoring without a TAP

The EX2/EX2+ is connected inline on a live 1G or 10G optical link. Filters can be set up to copy traffic out on the 4 x 10/100/1000 Mbit Base-T interfaces. This traffic can be captured using a regular laptop with an installed protocol analyzer. This application has no impact on the live link due to the non-blocking backplane and very low delay of the Packetmaster series NPBs. Additionally, session-aware load-balancing is a standard feature and can be used to load-balance a copy of the live traffic to multiple capture tools (or multiple capture interfaces of a single tool).



Aggregation and filtering

The EX2/EX2+ is connected to several devices, e.g. SPAN ports, port mirrors or TAPs. The multiple traffic streams from these inputs can be aggregated into one data stream to be output to a monitoring device or security tool. This application reduces the overhead associated with each transmission. Load balancing can be used to distribute the traffic load across multiple capture tools. The traffic can also be filtered to ensure that only the traffic relevant to a given tool is forwarded to that tool while simultaneously reducing the risk of oversubscribing an interface.

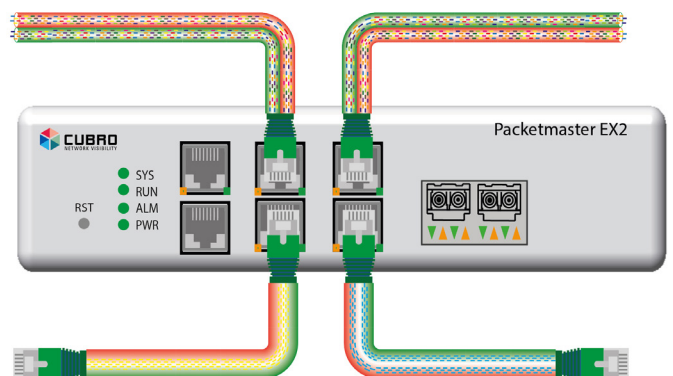



Bypass

A bypass is a hardware device that provides a fail-safe access port for an in-line active security appliance. The EX2/EX2+ monitors the health of the active inline appliance by sending heartbeat packets through the security appliance and detecting them after they have passed through the device. If the security appliance fails then the heartbeat will not be detected and the EX2/EX2+ can either reroute the traffic around the failed security appliance or reroute the traffic through a spare standby unit.

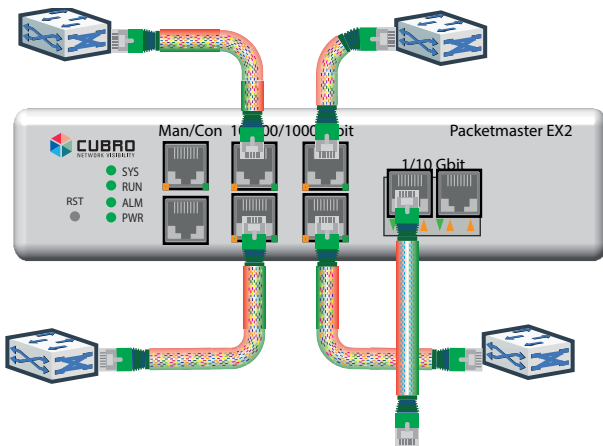

1 Gbit Copper Monitoring

The EX2/EX2+ is connected inline on a live 1G copper link. Filters can be set up to copy traffic out on the 4 x 10/100/1000 Mbit Base-T interfaces. This traffic can be captured using a regular laptop with an installed protocol analyzer. This application has no impact on the live link due to the non-blocking backplane and very low delay of the Packetmaster series NPBs. This application can also allow for specific traffic to be removed from the live link, modified, and reinserted into the traffic stream.



Media Converter

The EX2/EX2+ can also work as a media converter from:

- Copper to Fiber 1 Gbit
- Copper to Fiber 10 Gbit
- Fiber 10 Gbit (SM) to Fiber 10 Gbit (MM), etc.

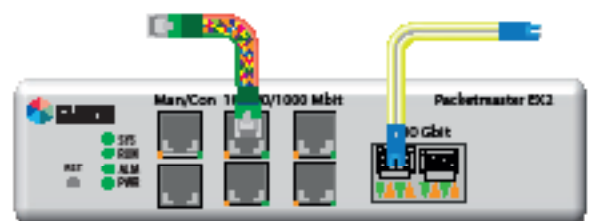

Media Converter

ADDITIONAL INFORMATION

EX2/EX2+ WebGUI

The EX2 series shares the same Graphical User Interface (GUI) as the rest of the Packetmaster series. The intuitive GUI allows the user to set up and change the configuration of the device faster and more easily than the traditional CLI. It also makes monitoring of filters, testing, and troubleshooting more efficient and streamlined.

- Compatible with all major, modern browsers.
- HTML5 based GUI; no Flash or Java required
- Support for mobile devices

App and Scripting

The Packetmaster series includes a GUI-based App Manager that allows the user to run a Python script within the Cubro environment. The Packetmaster devices natively support BASH and Python scripting out of the box.

Session Aware Load-balancing

Load-balancing is a vital function to distribute incoming traffic across different monitoring tools evenly. The EX2 supports Session-Aware Load balancing, meaning that every packet that belongs to the same conversation/flow is sent to the same output port within a load-balancing group.

Difference between EX2 and EX2+

The EX2+ is available with two built in Optical TAPs (1xLink SM 80/20 and 1xLink MM 50/50). The EX2+ includes a rugged, waterproof transport case with space for an additional power supply unit and cabling.

ORDERING INFORMATION

Part Number	Description
CUB.PM-EX2	Packetmaster EX2, 4x10/100/1000 Base-T and 2x1/10G
CUB.PM-EX2+	Packetmaster EX2+ Set, 4x10/100/1000 Base-T and 2x1/10G, including optical splitters
CUB.RM19-EX2-R3	19" Rackmount Kit for 1 Packetmaster EX2 and optional one R3 Rackmount TAP
CUB.RM19-EX2-2	19" Rackmount Kit for 2 Packetmaster EX2 series
CUB.PM-EX2-PS	EX2 additional power supply