

Cubro BIDI TAP

PRODUCT OVERVIEW



Cubro BIDI TAPs provide visibility to bidirectional links. The TAPs export monitored traffic gathered from two transmitted signals, providing complete coverage for analytic and security tools. There are new smart concepts of tapping a link with two different wavelengths over the existing infrastructure with BIDI SFP which transports up to 10 Gbit duplex over only one fibre.

A BIDI link uses one fibre to build a duplex link and helps to reduce costs (See Figure 1).

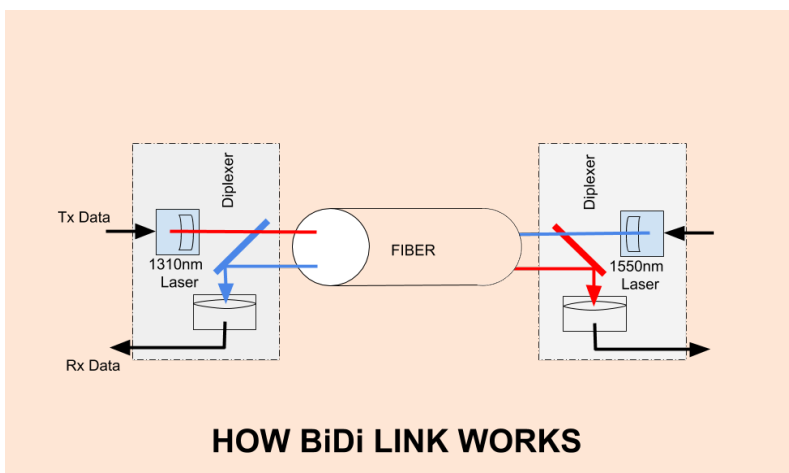

Fig. 1

Network TAP At a glance

Definition

A network TAP (Test Access Point) is an external monitoring device that mirrors the traffic that passes between two network nodes. A TAP is a hardware device inserted at a specific point in the network to monitor data.

Advantages of BIDI TAP

- Provides visibility to bidirectional traffic
- Full transparency, adds no delay
- Makes 100% copy of network data allowing the monitoring tools to see every bit, byte and packet
- No power supply needed, completely passive
- Cost-effective
- Low insertion loss
- Flexible and scalable
- Every used splitter inside the optical BIDI TAP is carefully handled

It is a challenge to tap such links, but Cubro can provide a solution to tap such a link and break it down into each signal with the use of the Packetmasters (See Figure 2).

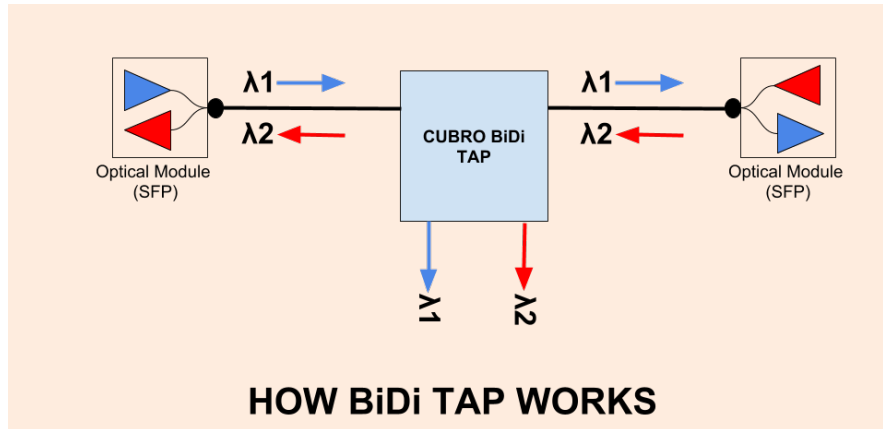

Fig. 2

The TAP, fully passive, is completely transparent and adds no delay to the network.

Functions / Benefits:

- The Cubro TAP works with each combination of BiDi SFP on the market
- Up to 3 BiDi TAPs can be mounted in one 19" rackmount kit which can be acquired optionally

PRODUCT CAPABILITIES / FEATURES

Tapping BiDi optical fibres	One link two fibres to two outputs
Fault Propagation	If the link on the input port is going down the output ports will follow with a short delay.
LED Indicator	No LED
No Power Needed	Fully passive
Propagation Delay (In-Out)	No delay at all
MTBF	N/A
Operating Temperature	0 to 55°C
Operating Humidity	80% maximum relative humidity
Physical Dimensions (H x W x D)	3 x 11,2 x 17 cm 1,8 x 4,4 x 6,7 in
Rugged Aluminium housing	Stable aluminium housing with precise connector labelling on the front panel. 19" Rack mount kit also available

ORDERING INFORMATION

Product Type & Number	Description
CBR.BIDI-SM-1-R3	Optical BIDI TAP SM, 1 Link SM LC-duplex, Monitor Ports SM LC duplex; 1/3 19" rackmount housing (rackmount kit not included)
CBR.RM19-3	CUBRO 19" Rackmount Kit for 3x 1/3 19" units

Cubro 40 Gb BIDI TAP

(For use with Cisco 40 Gbps BIDI QSFP)

PRODUCT OVERVIEW



Cubro 40 Gb BIDI TAPs provide visibility to bidirectional 40 Gb traffic. The TAPs export monitored traffic gathered from across all four transmit signals, providing complete coverage for analytic and security tools. There are new smart concepts of transporting 40 Gbit over the existing 10 Gbit infrastructure with BIDI QSFP which transports 40 Gbit duplex over only two fibres.

The BIDI QSFP multiplies two 20 Gbit lanes and sends this over a single fibre (bidirectional). See figure 1

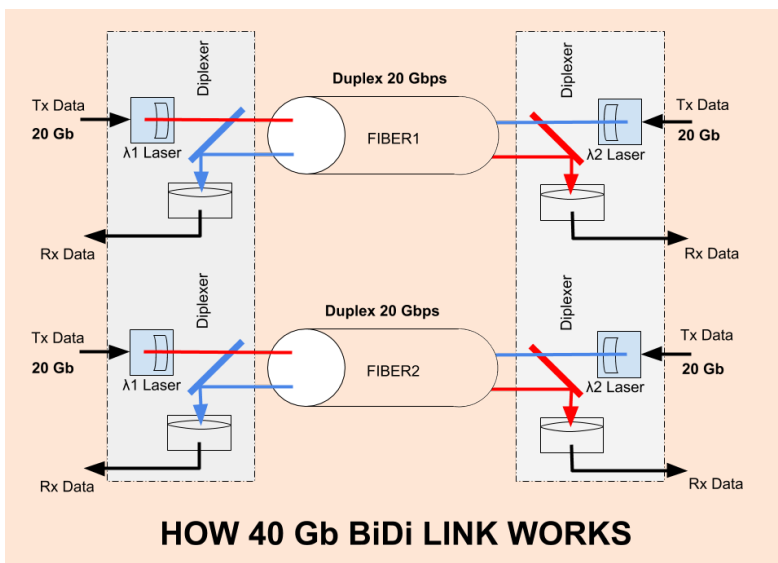

Fig. 1

Network TAP

At a glance

Definition

A network TAP (Test Access Point) is an external monitoring device that mirrors the traffic that passes between two network nodes. A TAP is a hardware device inserted at a specific point in the network to monitor data.

Advantages of BIDI TAPs

- Provide visibility to bidirectional 40 Gb traffic
- Full transparency, adds no delay
- Make 100% copy of network data allowing the monitoring tools to see every bit, byte and packet
- No power supply needed, completely passive
- Flexible and scalable
- Cost effective

It is a challenge to tap such links, but Cubro can provide a solution to tap such a link and break it down into multiple 20 Gbit streams with the use of the Packetmaster EX32+. See figure 2

Cubro 40 Gb passive BIDI TAP supports Cisco infrastructures using bidirectional 40 Gb transceivers. The TAP, fully passive, is completely transparent and adds no delay to the network.

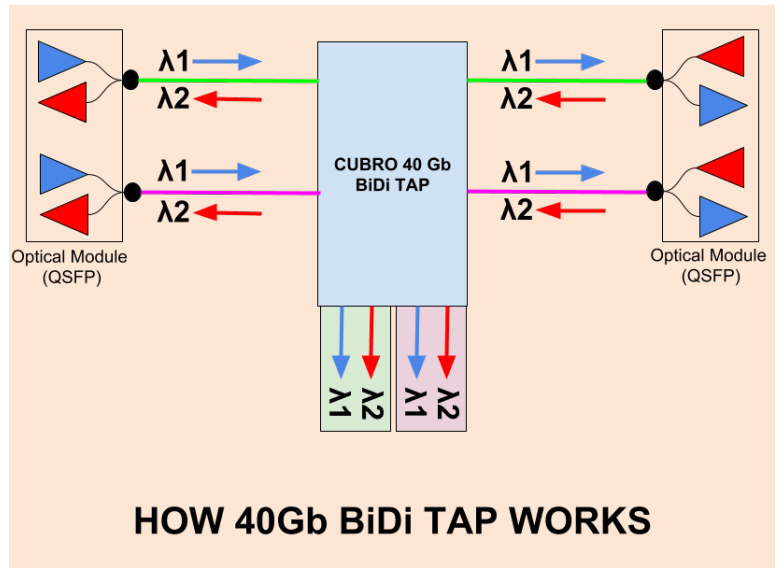

Fig. 2

Functions / Benefits:

- Opens visibility to higher-density 40 Gb BIDI links, leveraging newer bidirectional optics
- Supports Cisco infrastructures using bidirectional 40 Gb transceivers
- Up to 3 BIDI TAPs can be mounted in one 19" rack mount kit which can be acquired optional

PRODUCT CAPABILITIES / FEATURES

Tapping BIDI optical fibres	One link two fibres to two outputs
Fault Propagation	If the link on the input port is going down the output ports will follow with a short delay.
LED Indicator	No LED
No Power Needed	Fully passive
Propagation Delay (Into Out)	No delay at all
MTBF	N/A
Operating Temperature	0 to 55°C
Operating Humidity	80% maximum relative humidity
Physical Dimensions (H x W x D)	3 x 11,2 x 17 cm 1,8 x 4,4 x 6,7 in
Rugged Aluminium housing	Stable aluminium housing with precise connector labelling on the front panel. 19" Rack mount kit also available

ORDERING INFORMATION

Product Type & Number	Description
CUB.BIDI-MM-1-C-R3	Optical Bidi TAP MM, 1 Links CISCO BIDI SR, LC, rackmount housing (rackmount kit not included)
CBR.RM19-3	CUBRO 19" Rackmount Kit for 3x 1/3 19" units



hkaco.com



关注我们

需要详细信息? 请通过sales@hkaco.com联系我们 | 电话: 400-999-3848
办事处: 广州 | 北京 | 上海 | 深圳 | 西安 | 武汉 | 成都 | 沈阳 | 香港 | 台湾 | 美国